

Technical documentation for:

## **FREQUENCY-CONVERTER MFR 600A / 1500A**

**Version 2**

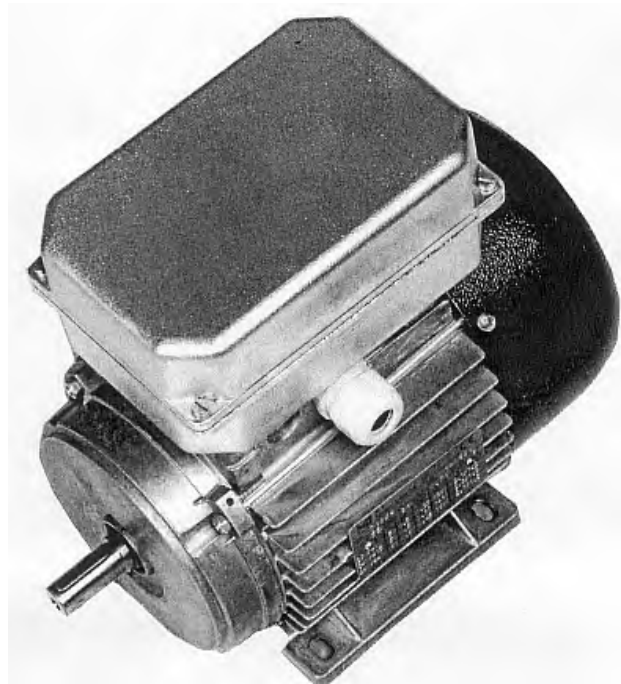

### **Contents:**

1. General description
2. Technical data
3. Function of the ramp generator
4. Electrical connection, examples for the control
5. Mechanical dimensions, assembling
6. Start of operation, adjustments
7. Safety considerations

## 1. General description

The frequency converter MFR 600 / MFR 1500 are designed for the speed - variation of standard 3-phase asynchronous induction motors from zero up to an adjustable maximum speed.

The mechanical design provides the assembling instead of the normal terminal case of a standard motor. By use of corresponding sealings protection levels up to IP68 are possible. The main advantage of the assembling on the motor is the fact, that the connections to the motor are inside of the closed metal case. This is very important because the radiation of this connection is prohibited and there is also no capacitive load for the inverter to drive. This reduces both the power losses and the RFI level on the mains.

The drives are working with a chopper frequency of appr. 10 kHz (switchable to 15kHz), providing smooth running of the motor also in the low-speed region.

The drives are designed for 2-quadrant operation (driving in both directions). Braking is possible up to a power level equal to the power losses of the motor. While breaking the induction of the motor is increased and therefore also the power losses of the motor.

By means of a DIP-switch (detailed description at 6.2) the drives can be switched to the following operation modes:

In the '**Normal - operation**' the frequency range reaches up to 150 Hz. In the low-speed range, the motor voltage can be increased by the adjustment of trimpot 'Boost' (P1). The increase of the motor voltage causes at zero speed a DC-current in the motor. This DC-current provides braking down to zero speed and is automatically switched off 4 seconds after reaching zero frequency. This switch off is necessary to avoid heat-up of the motor at zero speed.

In the '**Pump - operation**' - mode the maximum frequency reaches only 55 Hz, and the ramp time is fix at 5 sec. The trimpotis 'Boost' and 'Ramp' are in this operation mode not active. In This mode the voltage to frequency - ratio is reduced with the frequency. This reduces the power - losses of the motor at reduced speeds.

In the '**High - frequency - operation**' - mode the maximum frequency - range reaches up to 599 Hz. In this mode the trimpot 'boost' is used to adjust the required voltage to frequency - ratio.

In the operation - mode '**long ramp**' the ramp - time - adjustment - range is switched from 0.2-15 sec to 4 - 300 sec (for a frequency - step of 150 Hz / 599 Hz). This Mode is not combinable with the pump-operation mode.

The operation - mode '**Motorpot**' enables to control the speed of the drive by 2 keys (see 4.5).

The operation - mode '**200 Hz**' let the inverter automatically speed up to 200 Hz after switching on. The ramp-time is fixed to 1 sec, all control - signals and trimpotentiometers are inactive.

The selection of the required operation - mode without voltage on the mains and inside the inverter. After disconnecting the drive from the mains, the circuit needs appr. 30 sec to be free of voltage. After this time a switch from one to another operation - mode can be done.

For the connections of the mains, motor and control lines there are plug - in - terminals used. To protect the drive against dust, humidity, mechanical shock and vibrations the electronic unit is embedded in a soft casting resin inside an aluminium case.

The control - inputs of the drive are protection - isolated (in accordance with VDE 0884). The drives are also protected against a direct short between motor - lines or between motor - line and earth.

The electronic limiter of the motor - current allows at case temperatures up to 70°C a maximum motor - power of appr. 150 % of nominal power. The thermal - protection is switching off the drive at appr. 85°C. The reset of the thermal switch off must be done by switch off the mains for at least 10 sec.

To control the drive signals from potentiometer, ext. voltage 0...10V, ext. current 0...20 mA or 4...20 mA is possible. The adaption of the input - circuit to correspond to the control - signal is made by the jumper B1 and B2. **Attention!** If the input - circuit is set for control from a potentiometer or with 0...10 V, a disconnection of the control - input (terminal 2) causes a control signal of half the adjusted maximum! Open control - input is therefore to be avoided.

To enable the drive a closed loop must be connected to the enable - input.

The temperature protection circuit of the motor is designed to accept loops with up to 1040 ohm as closed loops, higher resistance values as open loops. This makes it possible to use a PTC - sensor or a thermistor in the motor.

The drive delivers an output signal (Inverter OK) if mains is ok and no error is detected.

Control - lines with a length of more than 2 meters must be shielded. The shield should be connected to terminal 4. Below the length of 2 meters shielding is recommended if a high disturbance - level is present in the surrounding.

## 1.) Technische Daten

	MFR 600	MFR 1500
Mains - voltage	230 V AC	230 V AC
With reduced load switchable to	115 V AC	115 V AC
Tolerance of the mains-voltage	± 15%	± 15%
Frequency of the mains-voltage	50 – 60 Hz	50 – 60 Hz
recommended fuse in the mains	6,3 A träge	10 A träge
rec. max. motor size	375 W	750 W
Nominal voltage of the motor	3x230 V AC	3x230 V AC
Motor - current (max. at 30°C case-temp.)	>3 A eff	5,5 A eff
Temperature - range (case - temperature)	0 – 70 °C	0 – 70 °C
Mechanical size	150 x 100 x 70	150 x 100 x 70
Weight	0,85	0,88
<b>Output - frequency - ranges:</b>		
- Normal - operation	0 – 150 Hz	
- Pump - operation	0 – 55 Hz	
- High - frequency - operation	0 – 595 Hz	
Adjustment - range of the min. frequency (trimpot P4)	0 – 50%	
<b>Ramp - times:</b>		
Normal - operation, frequency - step = 150 Hz		
- DS 5 off	0,1 – 15 sec	
- DS 5 on	4 – 300 sec	
High - frequency - mode, frequency step = 595 Hz		
- DS 5 off	0,2 – 15 sec	
- DS 5 on	1,5 – 250 sec	
Pump - operation - mode, frequ. step = 55 Hz	7 sec	
200 Hz - operation - mode	1 sec	
<b>Control - signals:</b>		
B1 and B2 open	Potentiometer od. ext. Spannung 0-10V	
B1 closed, B2 open	0 - 20 mA	
B1 and B2 closed	4 - 20 mA	
<b>Input - resistance of the control - input:</b>		
B1 open	> 500 kohm	
B1 closed	470 ohm	
<b>Enable - signal:</b>	closed loop or +24V / 3-5 mA DC	
<b>Reversing - signal:</b>	open / closed loop or +24V / 3-5 mA DC	
<b>Temperatur protection input:</b>	closed loop with R < 1040 ohm Loop current appr. 1 mA	
<b>Inverter OK - output:</b>	open collector NPN, max. 27V/100 mA	

### 3. Function of the ramp - generator:

3.1 Normal - or high - frequency - operation - mode:

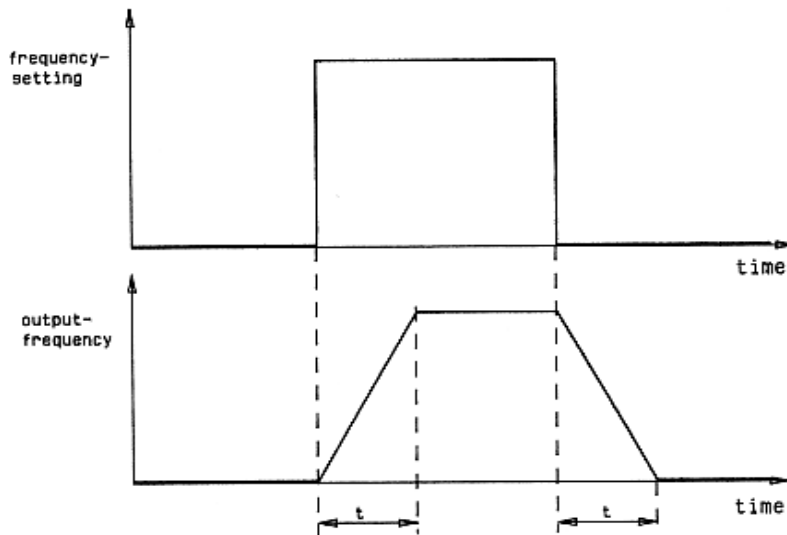

The adjustment of the ramp - time is made by trimpot P2.

With DS 5 'off' the range of t is 0.1 ... 15 sec. (for a frequ. step of 150 Hz resp. 599 Hz)

With DS 5 'on' the range of t is 1.5 ... 250sec.

3.2 In the mode 'pump - operation' the ramp - time is fixed to 7 sec. (for a frequ. step of 55 Hz).

3.3 In the operation - mode '200 Hz' the ramp time is fixed to 1 sec.

### 4. Electrical connection and examples for the control of the drive:

4.1 Control by potentiometer:

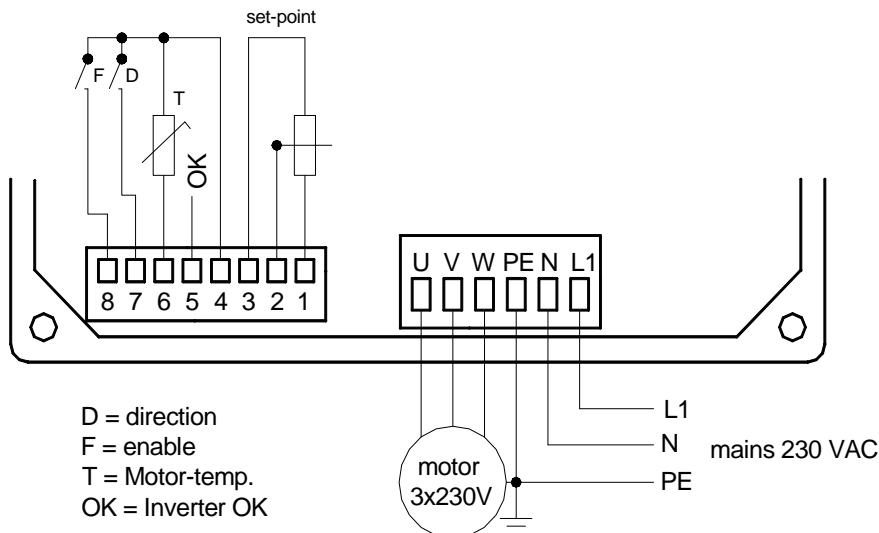

## ANGETRIEBEN VON INNOVATION, geleitet von Erfahrung

### 4.2 Control by external voltage 0...10 V DC:

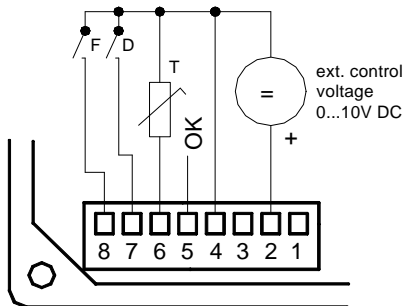

D = direction  
 F = enable  
 T = Motor-temp.  
 OK = Inverter OK

### 4.3 Control by external current 0...20 mA DC (4 ... 20 mA DC):

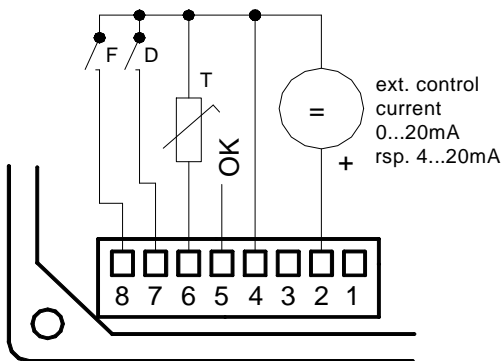

D = direction  
 F = enable  
 T = Motor-temp.  
 OK = Inverter OK

### 4.4 Control by 2 keys in the mode 'Motorpot':

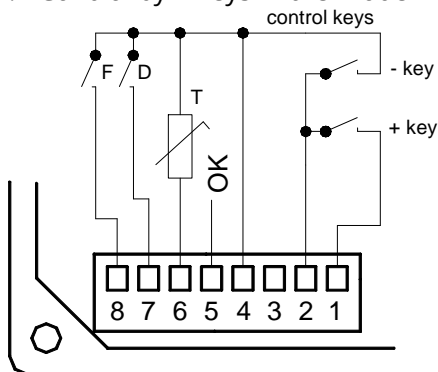

D = direction  
 F = enable  
 T = Motor-temp.  
 OK = Inverter OK

**5. Mechanical dimensions, assembling on the motor:**

(Drawn is one possible assembling. In accordance with the requirements the drive can also be assembled in different modes)

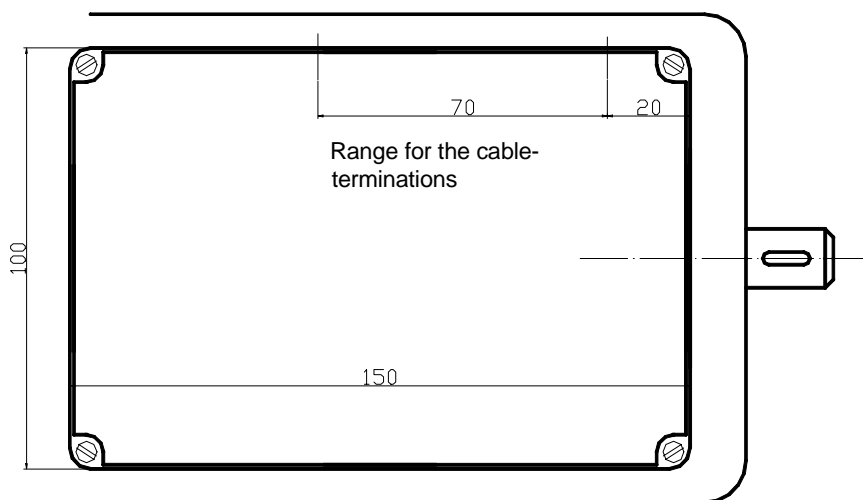
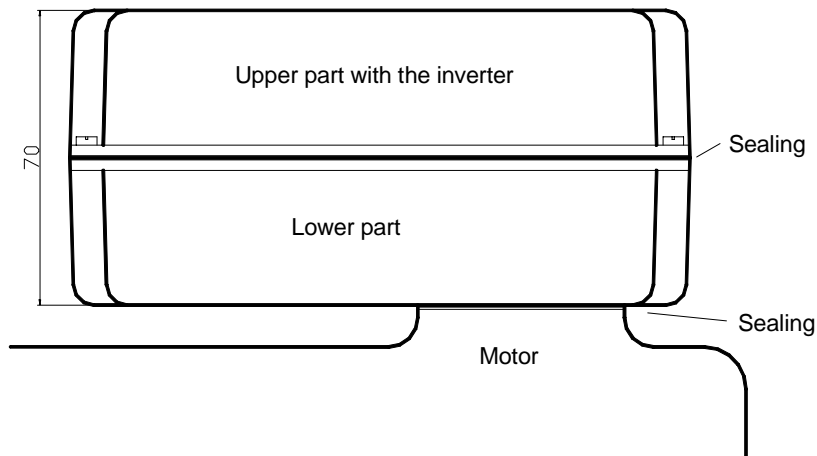

**Assembling - steps:**

1. Drilling and milling of the lower part of the case in accordance with the flange of the motor - terminal - case. Drilling the holes for the cable - terminations. **Caution!** Take care that the capacitors of the drive do not bump into the terminals of the motor!
2. Assembling of the lower part of the case on the motor.
3. Assembling of the cable - terminations.
4. Assembling and fastening of the cables.
5. Connecting of the plug-in - terminals to the wires of the cables and the motor.
6. Placing the seal.
7. Plug - in the connectors to the converter.
9. Fixing of the upper case on the lower case.

**6. Start of operation, adjustments:**

Because of the fact, that an adjustment is impossible if the drive is assembled, parameters and limits must be adjusted before assembling.

It is recommended to make the requ. adjustments within the incoming inspection.  
For OEM applications we offer as a special service without additional costs to make the adjustments within the final inspections in our house.

6.1 Position of the switches, jumpers and trimpots:

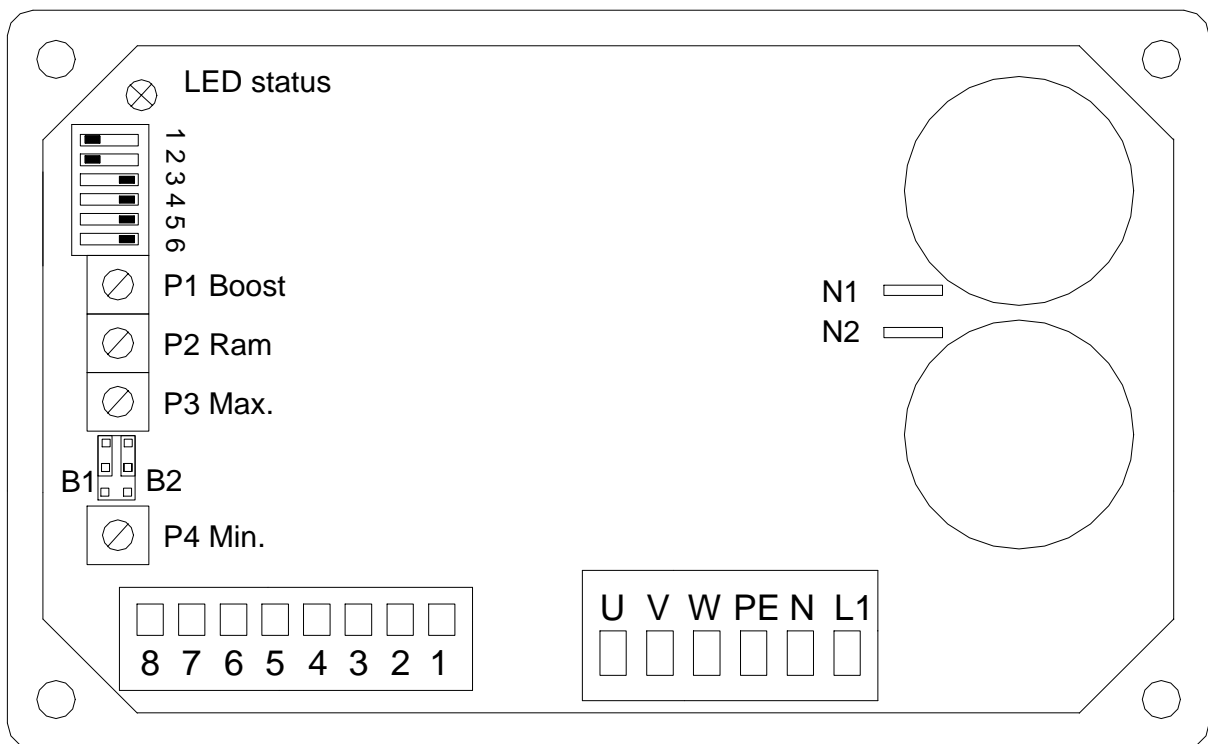

6.2 Selection of the requ. operation - mode:

	DS1	DS2
Normal operation	ON	ON
Pump operation	OFF	ON
High frequency operation	ON	OFF
Not useable	OFF	OFF

Selection of the requ. Additional modes (can be combined):

Control mode 'Motorpot'	DS 3 ON
Clock frequency 16 kHz	DS 4 ON
Long ramp time	DS 5 ON
Inverter not self - starting	DS 6 ON

Selection of the control modes:

Control by potentiometer or ext. Voltage 0...10V:    B1 and B2 open  
Control by current 0...20 mA:                        B1 closed, B2 open.  
Control by current 4...20 mA:                        B1 and B2 closed.

**6.3 Adjustment of the trimpotis in the 'Normal - operation' - mode:**

- 6.31 Connect mains, motor and control - circuits.
- 6.32 Switch on mains, close the enable - loop.  
Turn set - point - potentiometer to the maximum CW.  
Adjust the requ. maximum speed at trimpot P3.
- 6.33 Turn set - point - potentiometer to the maximum CCW.  
Adjust the requ. minimum speed at trimpot P4.
- 6.34 Turn the set - point - potentiometer fast from CCW to CW and return.  
Adjust the requ. ramp time at trimpot P2.
- 6.35 If in the low - speed -range additional torque is necessary, adjust the boost - ratio.  
at trimpot P1.

**6.4 Adjustment of the trimpotis in the 'High - frequency' - operation mode:**

The adjustment runs similar to 6.31 - 6.34. The requ. voltage to frequency - ratio must be adjusted at trimpot P1, the 'boost' - function is inactive.

**6.5 Adjustment of the trimpotis in the 'Pump - operation' - mode:**

The adjustment runs similar to 6.31 - 6.33, steps 6.34 and 6.35 are inactive.

After these adjustments the converter - unit can be assembled on the motor and operation can start.

**7. Safety considerations**

The following safety considerations must be observed during all phases of operation, service and repair of this device. Failure to comply with these precautions violates the intended use of this device.

To minimize the shock - hazard the drive must be connected to an electrical ground. Terminal PE or the metal-case must be connected to the electrical ground (safety - ground) of the power - outlet.

Do not operate in an explosive atmosphere! Operation of this device in the presence of flammable gases, fumes or dusts may cause of an ignition of this atmosphere and is to prevent.

## ANGETRIEBEN VON INNOVATION, *geleitet von Erfahrung*

### CAUTION!

To prevent potential shock hazards do not expose this device in the open state to moisture, rain or wetness. Wetness inside the case may cause an electrical connection between mains and the inputs.

Installation, adjustment and service of this device must be made by qualified personal. Works at the electrical parts of the device are very dangerous because of the high voltage the device is working with. This high voltage is capable of causing death and is present even after disconnecting mains. Before starting of service, it is necessary to wait at least 30 sec. after disconnecting mains.

This device must not used as an electrical disconnection. It is not allowed to work at the output lines without a mechanical disconnection from mains, even if the driven motor does not carry voltage or current.

Do not attempt internal service or adjustment unless another person, capable of disconnecting mains and rendering first aid is present.

Do not touch the electrical parts of this device. During operation the electrical parts are carrying dangerous voltages. Out of operation a touch may cause a defect by electrostatic discharge.

To prevent additional hazards, do not make modifications at this device.